



A Short Review on Comparative Analysis of Depth(d) To Weight (w) Ratio (d:w) of Existing Water Robot

Rakesh Rajendran^{1,*}, Sumithra. K.¹, Hamsadhvani.V.¹, Gokulanathan. A.², Shivakumar. N.¹

ARTICLE INFO

Article history:

Received 02 May 2025;
in revised from 01 Aug 2025;
accepted 05 Sep 2025.

Keywords:

Remotely Operated Vehicle (ROV), (AUV)-Automated Underwater Vehicle, Shallow robots, Deep sea robots, Marine robots, depth to weight ratio(d:w).

ABSTRACT

The term Robotics has become one of the hot topics in this era of technology, the field robotics has evolved in a wide range based on its application. Its invasion has become inevitable serving the human community by ensuring that making things which are impossible to possible. Water Robots is one such field. Though there are lot of researchers across the globe working on this area proposing their innovative design with add on features compared to the existing one. Water robots includes both marine robots and fresh water robots. This marine robotics can be employed for deep sea exploration, exploring extra-terrestrial organism in other planet, rescue operation serving as life boat saving human life, surveillance of deep-sea ecosystem or underwater photography, under water infrastructure maintenance and environmental monitoring. The design of these under water robots lies with various constraints and challenges like weight and power capacity (ROV-remotely operated Vehicle having power cable connected with robot) and (AUV-Automated Underwater Vehicle working without power cable), dimension of the robot, depth that the robot can reach (shallow robots (robots that can reach to the depth less than 6000m) and deep-sea robots (reaching depth more than 6000 meters). Since the scope for improvement in the design of these underwater robots is more while considering the design constraints, there is a need for a comprehensive comparative analysis of these design constraints for the existing under water robots in terms of depth to weight (d:w)ratio analysis. In this article, an exhaustive survey is made considering all existing under water robots categorized based on its mode of application. The study not only limits with classification but also enables the readers to compare the value of design constraints in the existing under water robot. This knowledge enhances the researcher for better understanding of existing marine robots based on which a new innovative design could be arrived overcoming the benchmark.

© SEECMAR | All rights reserved

1. Introduction.

The possible classification of marine robot based on the mode of application is as shown in Fig 1. The marine robots can be classified as on water surface robot, unmanned under water vehicle and hybrid type which can move on the surface and under the water surface. These classifications are further sub divided as Remotely Operated Vehicle (ROV), Automated

vehicle and Autonomous underwater vehicle. The HOV (human Occupied Vehicle) and submarine are not considered as underwater robots.

The Autonomous Underwater Vehicle is further classified based on the locomotive type as under water drones, wheeled type under water robots, legged type under water robot and floating type under water robot. The floating type under water robot are further classified as bioinspired, with propeller and without propeller. The Autonomous Underwater Vehicle is further classified based on the locomotive type as under water drones, wheeled type under water robots, legged type under water robot and floating type under water robot. The floating type under water robot are further classified as bioinspired, with propeller and without propeller.

¹Periyar Maniammai Institute of Science and Technology.

²School of Nautical Studies, Indian Maritime University-Chennai Campus.

*Corresponding author: Rakesh Rajendran. E-mail Address: rak2win@gmail.com.

It is understood that for a water robot to reach a deeper depth, the more weight would be a constraint as the pressure gets increased as the robot descend the depth. On other side, ballast tanks are introduced to fine tune the robot weight with its buoyancy. But these ballast tanks also contribute towards increasing the weight of the water robot. Hence a proper study is required to understand the existing design with high depth to weight ratio. And this short review on existing water robot has helped us to find the depth to weight ratio value of each so far proposed design.

2. Literature Survey.

The literature survey is done based on the classification as shown in Figure 1. The individual comparison is made in each type with respect to the depth it can reach, length and weight of the proposed under water robots developed by different authors.

2.1. Surface Water Robots.

These robots travel on the surface of water. This is broadly classified as remotely operated and autonomous surface water vehicle or robot. It can be applied in rescue operations, eliminating hazardous floating waste in the water, removing crude oil in the ocean floating because of the ship accidents etc. The table 1-4 shows the comparison of existing surface water robots. The surface water robot developed by Ranmarine technology [1] can travel a depth of 300 cm having a length of 190 cm and weight of 39 kg as shown in Figure 2. The d:w value is of this robot is 0.076. Thomas et al [2] proposed one surface robot having a length of 2m and weight of 80 kg, this under water robot was developed by ASV Global as shown in Figure 3. Rahmawati et al [3] Figure 4 proposed surface water robot with length of 1200mm and weight of 8kg in simulation mode. Otter [4] is a surface water robot as shown in Figure 5, developed by Maritime Robotics having a weight of 150 kg and length of 2.1m, it is used for shallow water surveying, environmental monitoring and scientific data collection. Xin Sun et al [5] has proposed a salvage cleaning water surface robot as shown in Figure 6. The specification of this bot is unavailable. Unmanned moving boat [6] is an intelligent ecological maintenance robot as shown in Figure 7, having length of 4000m and weight of 1100 kg. Karl von Ellenrieder, FaU [7] developed unmanned surface vehicle as shown in Figure 8 which is of length 1.78m and weight of 150 kg. Orsted [8] offshore wind farm developed as shown in Figure 9, a hugin uncrewed vessel for offshore metocean measurement campaign having length of 9m and weight of 6800kg. Automated surface vehicle [9] as shown in Figure 10, developed by German Research Center for Artificial Intelligence GmbH is of weight 300-500kg and length of 4m. Beatbot [10] as shown in Figure 11, is a pool surface cleaning robot which is of length 0.45m and weight of 9.3kg. Intelligent water surface robot for microbial control of water pollution developed by Wu, Xiaoyan and Wang, Shu [11] is of 0.2m length and 107 kg weight as shown in Figure 12. MIT’s SENSE able City Laboratory developed seaworm [12] as shown in Figure 13, for cleaning the oil spill having the length of 4.8m.

Aanderaa Sailbuoy wind driven [13] ASV developed by off-shore sensing AS having weight of 60kg and length of 2 meters as shown in Figure 14. Smartium clean [14] developed by Koc, defense turkey is a sea surface cleaning robot as shown in Figure 15, having weight of 52kg and length of 0.95m. A robotics lilypad [15] over the surface of lagoon for environmental monitoring is developed by Developed by the Laboratory for Underwater Systems and Technologies at the University of Zagreb is of 1m length and weight of 20 kg as shown in Figure 16. Unmanned pool cleaning robot as shown in Figure 17 developed by Sichuan Dongfang Water Conservancy Intelligent Equipment & Engineering Co., Ltd [16] is of length 0.65m and weight 5kg. Magura V5[17] developed by Ukraine war fueling development of uncrewed surface boat as shown in Figure 18 carries weapons and its having weight of 1000kg and length of 5.5m. Mahi two[18] uncrewed surface vehicle is of length 4m as shown in Figure 19. Sunnysvale, California[19] as shown in Figure 20, has developed Wave Glider from Liquid Robotics which is of autonomous, unmanned surface vessel (USV) having a weight of 250kg and length of 3.5m. Smurf [20] developed by Orcaboat as shown in Figure 21, is an unmanned surface cleaning robot having length of 2.9 m and weight of 155 kg.

Figure 1: Classification of Water Robots or Marine Robots.

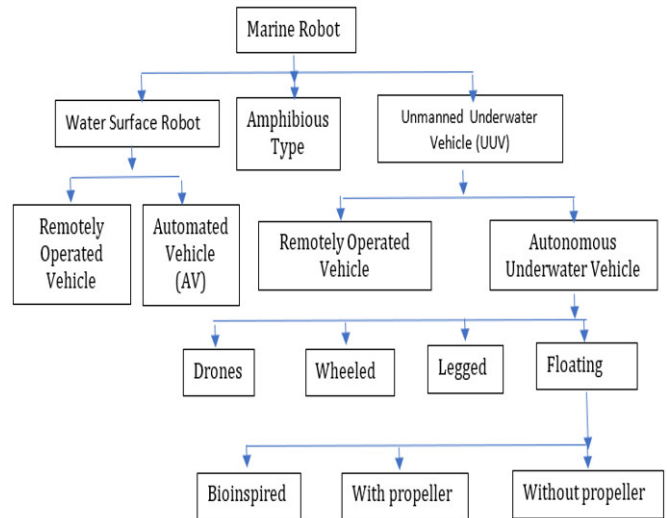

Source: Authors.

2.2. Under Water Robots.

These robots travel on the under the surface of water. This is broadly classified as remotely operated and autonomous under water vehicle. It can be applied in deep sea exploration, ocean survey, understanding aquatic ecosystem, discovering the wonders in deep sea etc. The table 5 -10 shows the comparison of existing under water robots. The Scarlet knight developed by Rutgers university [21] having self-weight of 60kg and can explore a depth of 100-150 meters having a length of 2.2 meters as shown in Figure 22. Slocum Glider (RU27) [22] as shown in Figure 23 can travels depth up to 1000 meters having a length of 2.1 m and weight of 40kg. These under water robots comes

under floating type without any propeller. Cotsbot as proposed by QuT [23] having length of 1.5 meters. And it is weighing around 60kg is able to descend at a depth of 100m as shown in Figure 24. The Autosub 6000 as shown in Figure 25 is having a length of 5.5 m and weight of 1800 kg descend to a depth of 6000m which comes under the category deep sea was developed by UK national oceanography center [24].US military developed Bluefin 9,12, and 21 [25-27] as shown in Figure 25. The Blue fin -9 is a shallow type descending to a depth of 300m having a length of 1.5m and weighing 140 kg. The Blue fin -12 is also shallow type descending to a depth of 1000m having a length of 2.4 m and weighing around 220 kg. The Blue fin -21 is a deep-sea type descending to a depth of 4500m having a length of 4.9m and weighing around 1700 kg. France Victor 6000[28] developed is an Remotely operated vehicle as shown in Figure 26, can descend to a depth of 6000 m, having a length of 4.3 m and weight of 5500 kg. Kaiko[29] is a deep sea type developed by Japan as shown in Figure 27 and it is remotely operated vehicle that can descend to a depth of 10,911m with a length of 3.6m and weight of 2600kg .Fendouzhe[30] is a deep sea robot as shown in Figure 28 developed by China ship building industries co-operation having a potential to descend a depth of 10,909 m with length of 9m and weight of 22,500kg.Sadao Kawamura [31] developed Shinkai as shown in Figure 29 with length of 9m and weight of 19000 kg .It is capable of descending to a depth of 6500 kg. Aqua explorer as shown in Figure 30 designed by Kato et al [32] is having a length of 3 to 4m with a weight of 200kg reaches a depth of 1000m.Twin Berger as shown in Figure 31 developed by Fuji et al [33] can reach to a depth of 2000m having a length of 4m and weight of 1000kg. Monterey Bay Aquarium Research Institute (MBARI)[34] as shown in Figure 32 has developed MBARI's Ventana which can reach a depth of 4000m having a weight of 3000kg and length of 5m.ABE as shown in Figure 33,is a shallow type under water robot that reaches a depth of 4500 m having a weight of 1000kg and length of 3.5m was proposed by Yoerger et al[35].ODIN a deep sea under water robot as shown in Figure 34 was developed by Choi et al[36] having a weight of 1200kg and length of 5m ,able to descend a depth of 6000m. Marius as shown in Figure 35, developed by Pascoal et al [37] reaches a depth of 2000m having a length of 3m and weight of 500kg . Parent -child is a shallow type under water robot as shown in Figure 36 developed by Juhwan Kim et al [38] reaches depth of 100m, parent weighing 210kg and child weighing 8.6kg.VORTEX is shallow type under water robot with a length of 3m and weight of 1000 kg developed by Rigaud et al [39] reaches a depth of 3000 as shown in Figure 37. Un-X under water robot developed by LPRC [40] (Ls Palms research Centre) is a shallow type reaching a depth of 500m, having a length of 0.6m and weight of 112 kg. It is moving in speed of 0.5m/s. The HROV (Hybrid remotely operated vehicle) as shown in Figure 38, reaches a depth of 6500m, it is of length of 1.2m and weight of 1500kg.It is a deep-sea type developed by JAMSTEC (Japan Agency for Marine Earth Science and Technology) [40]. Blue ROV2[41] as shown in Figure 39 developed by US based company named Blue Robotics, is a shallow type under water robot that reaches 100m depth, it is having a weight of 9.97kg and

length of 0.457m. Notilo plus [42] developed by French company is an underwater drone powered by Nvidia Jetson for AI feature, it reaches a depth of 60m and having weight as 9kg and length of 0.6m as shown in Figure 40. Mission specialist Defender [43] developed by US based company is an remotely operated vehicle reaching a depth of 305m and having a length of 0.85m and weight of 22.5 kg.

Table 1: Comparing the existing Surface Water Robot.

Name	Waste Shark	Thomas	Rahmawati et al	OTTER
Depth	300 cm	surface	Surface	surface
Length/diameter	190cmx140cmx45 cm	2 meters	1.2m	2.1m/1m
Weight	39 kg	80 kg	8 kg	150kg
Developed by	Ranmarine technology	ASV Global	Rahmawati et al	Maritime Robotics
depth:weight	0.076	0	0	0
Figure	2	3	4	5

Source: Authors.

Table 2: Comparing the existing Surface Water Robot-Continuation.

Name	Unmanned mowing boat	USV	ASV	Beatbot	
Depth	Surface	Surface	Surface	Surface	
Length/diameter	4000meters	1.78meters	9meter	4meter	0.45meter
Weight	1100kg	150kg	6800kg	300-500kg	9.3 kg
Developed by	-	Karl von Ellenrieder, FaU	Orsted	German Research Center for Artificial Intelligence GmbH	Beatbot
depth:weight	0	0	0	0	0
Figure	7	8	9	10	11

Source: Authors.

Table 3: Comparing the existing Surface Water Robot-Continuation.

Name	Intelligent surface robot for microbial control of pollution	Seaswrm	Aanderaa Sailbuoy wind driven ASV	Smartium Clean	A robotics lily pad over the surface of lagoon
Depth	Surface	Surface	Surface	Surface	Surface
Length/diameter	0.2meter	4.8meter	2meter	0.95meter	1meter
Weight	107kg	ina	60kg	52kg	20kg
Developed by	Wu, Xiaoyan and Wang	MIT's SENSEable City Laboratory	Offshore sensing AS	Koc, defense, turkey	Developed by the Laboratory for Underwater Systems and Technologies at the University of Zagreb
depth:weight	0	0	0	0	0
Figure	12	13	14	15	16

Source: Authors.

Table 4: Comparing the existing Surface Water Robot-Continuation.

Name	Unmanned Pool Cleaning Robot DF-H7	Magura V5	Uncrewed surface vehicle	Wave Glider	SMURF
Depth	Surface	surface	surface	surface	surface
Length/diameter	0.65meters	5.5meters	4meters	3.5meters	2.92 meters
Weight	5kg	1000kg	Ina.	250kg	155kg
Developed by	Sichuan Dongfang Water Conservancy Intelligent Equipment & Engineering Co., Ltd.	Ukraine war fueling development of uncrewed surface boat as weapons	Mahi two	Sunnyvale ,calif	Orcaubot
depth:weight	0	0	0	0	0
Figure	17	18	19	20	21

Source: Authors.

Figure 2: Waste Shark SWR.



Source: Ranmarine technology.

Figure 3: Thomas SWR.



Source: ASV Global.

Figure 4: Rahmawati SWR.

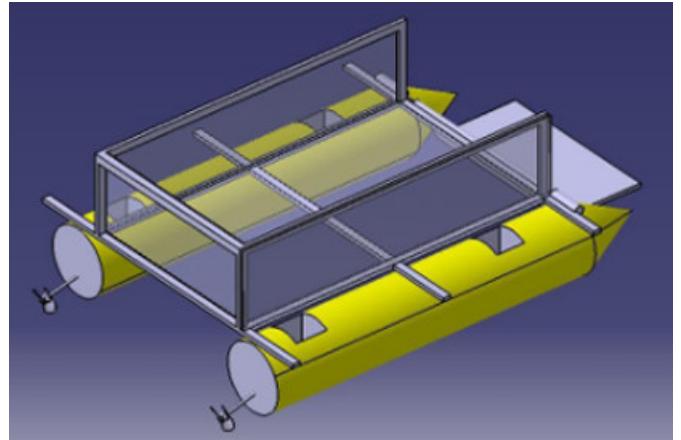

Source: Rahmawati et al.

Figure 5: Otter SWR.



Source: Maritime Robotics.

Figure 6: Salvage cleaning robot.

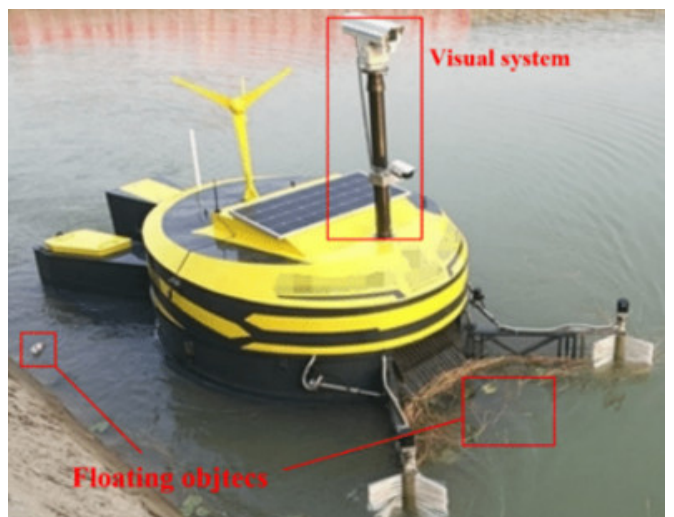

Source: Xin Sun et al.

Figure 7: Unmanned moving robot.



Source: China.

Figure 10: Automated Surface vehicle.

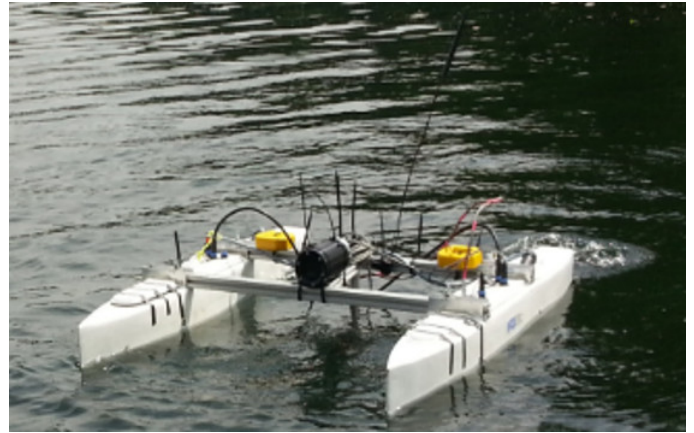

Source: GmbH.

Figure 8: Ellenrieder SWR.



Source: Ellenrieder et al.

Figure 11: Beatbot SWR.



Source: Beatbot.

Figure 9: Orsted et al SWR.



Source: Orsted et al.

Figure 12: Intelligent SWR.



Source: Wu, Xiaoyan etc.

Figure 13: Seaworm.



Source: Wu, Xiaoyan etc.

Figure 16: Robotic lily pad Clean.

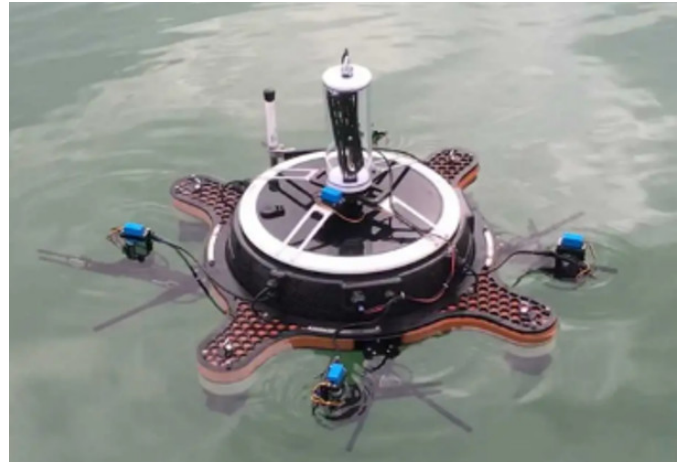

Source: University of Zagreb.

Figure 14: Aandera Sailbuoy.



Source: Offshore sensing AS.

Figure 17: Unmanned pool cleaning robot.



Source: Sichuan.

Figure 15: Smartium Clean.



Source: Offshore sensing AS.

Figure 18: Magura V5.



Source: Ukraine war fueling.

Figure 19: Uncrewed surface vehicle.



Source: Mahi two.

Figure 20: Wave Glider.



Source: Sunnyvale, Calif.

Figure 21: SMURF.

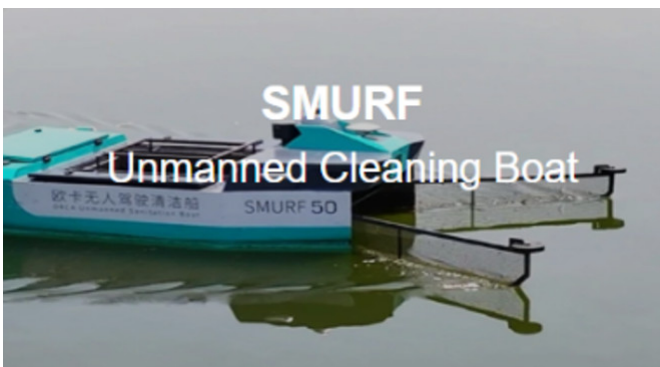

Source: Orcaboat.

2.3. Under Water Bioinspired Robots.

These robots travel on the under the surface of water. The body design of this robot is replicating any living organism under water. It can be applied in deep sea exploration, ocean survey, understanding aquatic ecosystem, discovering the wonders in deep sea etc. Table 11,12 shows the types in this category.

China, Shenyang Institute of Automation[44] developed a deep-sea type Qianlong having a length of 4m and weight of 1500 kg descends to a depth of 6000m as shown in Figure 42. Haido[45] is another deep sea type under water robot developed by Shenyang Institute of Automation, China as shown in Figure 43, with length of 6m and weight of 2500 kg descends to a depth of 7000m.

Jiulong[46] is developed by China as shown in Figure 44, which is of deep sea type descending to a depth of 7,062m having a length of 8m and weight of 22,000kg.

Bionic dolphine[47] is a bioinspired shallow type under water robot with length of 4m and weight of 181kg can descend to a depth of 6m as shown in Figure 45. SOFI robotic fish[48] developed by MIT professors has length of 1m and weight of 2.5 kg as shown in Figure 46.

This shallow type bioinspired under water robot can descend to a depth of 0 to 18m. The robot Jelly Fish[49] is another bioinspired shallow type under water robot developed by Florida Atlantic University (FAU) and the U.S. Office of Naval Research scientists as shown in Figure 47.

This jelly fish robot weight 650gm and has a length of 1.2 m and could descend to a depth of 300m. ChenjieZhang et al[50] developed a shallow type bioinspired Mantra Ray which is of length of 0.54m can descend to a depth of less than 1000m as shown in Figure 48.

Snake like water robot[51] developed by Norwegian company in collaboration with Kongsberg maritime reaches a depth of 500m and having a length of 2 -5 m and weight of 70-80kg as shown in Figure 49.

Humanoid under water robot[52] is a shallow type under water robot developed by Standford university is of weight 250 kg and length of 1.5 m reaches a depth of 1000m as shown in figure 50.

Table 5: Comparing the existing Under Water Robot.

Name	Scarlet Knight	Slocum Glider (RU27)	Cotsbot	Autosub 6000
Depth	100-150 meters	Upto 1000 meters	100 m	6000m
Length/diameter	2.2 meters/18cm	2.1 meters/20cm	1.5 meters	5.5m/0.9meters:
Weight	60 kg	40 kg	60kg	1800 kg
Type based on depth	Shallow	Shallow	Shallow	Deep sea
Developed by	Rutgers University		Qut University	UK national oceanography centre-AUV
depth:weight	2.5	25	66.66	3.33
Figure	22	23	24	25

Source: Authors.

Table 6: Comparing the existing Under Water Robot-Continuation.

Name	Bluefin-9small	Bluefin-12medium	Bluefin-21large	France Victor 6000
Depth	300 meters	1000 meters	4500 meters	6000 meters
Length/diameter	1.5m/0.4meters	2.4m/0.5meters	4.9m/0.9meters	4.3 m/2.5meters
Weight	140kg	220kg	1700kg	5500 kg
Type based on depth	Shallow	Shallow	Deep sea	Deep sea
Developed by	US military			France-ROV
depth:weight	2.14	4.54	2.64	1.09
Figure	25-A	25-B	25-C	26

Source: Authors.

Table 7: Comparing the existing Under Water Robot-Continuation.

Name	Kaiko	Fendouzhe	Shinkai	AQUA EXPLORER
Depth	10,911meters	10,909meters	6500meters	1000meters
Length/diameter	3.6m/2.3meters	9m/2.8meters	9meters	3-4meters
Weight	2600kg	22,500 kg	19000kg	200kg
Type based on depth	Deep sea	Deepsea	Deepsea-rov	shallow
Developed by	Japan-ROV	Chia ship building industry corporation	Sadao Kawamura, Japan	Kato et al
depth:weight	4.18	0.48	0.34	5
Figure	27	28	29	30

Source: Authors.

Table 8: Comparing the existing Under Water Robot-Continuation.

Name	TWIN BURGER	MBARI's Ventana.	ABE	ODIN
Depth	2000meters	4000meters	4500meters	6000meters
Length/diameter	4meters	5meters	3.5meters	5meters
Weight	1000kg	3000kg	1000kg	1200kg
Type based on depth	shallow	shallow	Shallow	Deep sea
Developed by	Fujii et al	Monterey Bay Aquarium Research Institute (MBARI)-ROV	Yoerger et al.	Choi et al.
depth:weight	2	1.33	4.5	5
Figure	31	32	33	34

Source: Authors.

Table 9: Comparing the existing Under Water Robot-Continuation.

Name	MARIUS	Parent-child	VORTEX
Depth	2000meters	100m(p) 100 m(child)	3000meters
Length/diameter	3-4meters	Parent 0.9m/1.5meters Child 0.38m/0.38m	3m/0.5meters
Weight	500kg	Parent-210kg Child -8.6 kg	1000kg
Type based on depth	Shallow	Shallow	shallow
Developed by	Pascoal et al	Juhwan kim et al	Rigaud et al
depth:weight	4	0,47,11.62	3
Figure	35	36	37

Source: Authors.

Table 10: Comparing the existing Under Water Robot-Continuation.

Name	HROV (hybrid remotely operated vehicle)	BLUE ROV2 (remotely operated vehicle)	NITLO PLUS (1 bubble under water)	Mission specialist defender(rov)
Depth	6500 meters	100 meters	60 meters (197 FEET)	305meters (1000FEET)
Length/diameter	1.2 meters	0.457meters	60CM (23.6 INCH)	0.858meters
Weight	1500 TO 2500 KG (3300 TO 5500) POUNDS	9.97kg	9 kg 19.8 POUNDS	22.5KG 50 POUNDS
Type based on depth	Deep sea (hybrid vehicles)	Shallow water rov (blue robotic)	Shallow - water French company	Mid – depth
Developed by	JAMSTEC (japan agency for marine -earth science and technology)	us based company under water		Us-based company
depth:weight	4.33	10.03	6.66	13.55
Figure	38	39	40	41

Source: Authors.

Figure 22: Scarlet knight.



Source: Rutgers University.

Figure 23: Slocum Glider (RU27).



Source: Rutgers University.

Figure 24: Cotsbot.



Source: QuT University.

Figure 25: Autosub.



Source: UK National Oceanography.

Figure 26: Blue fin 9,12,21.

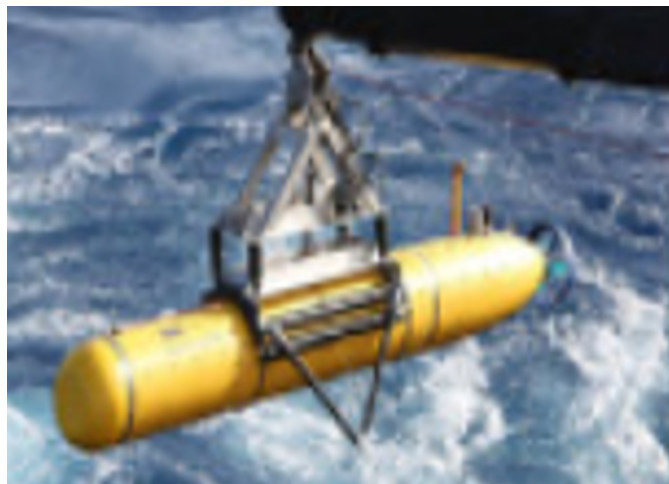

Source: US Military.

Figure 27: France Victor.

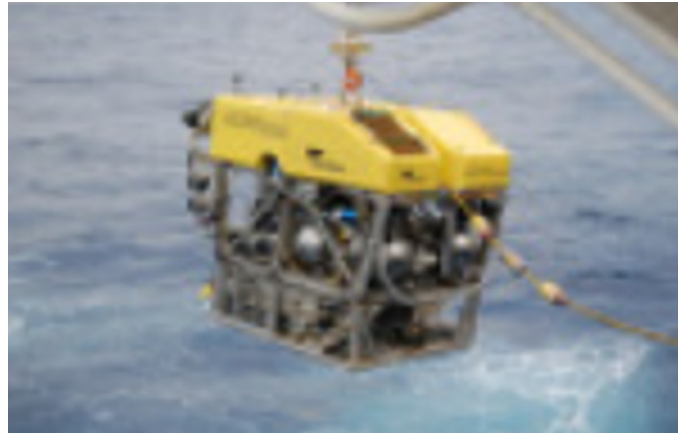

Source: UK National Oceanography.

Figure 28: Kaiko.

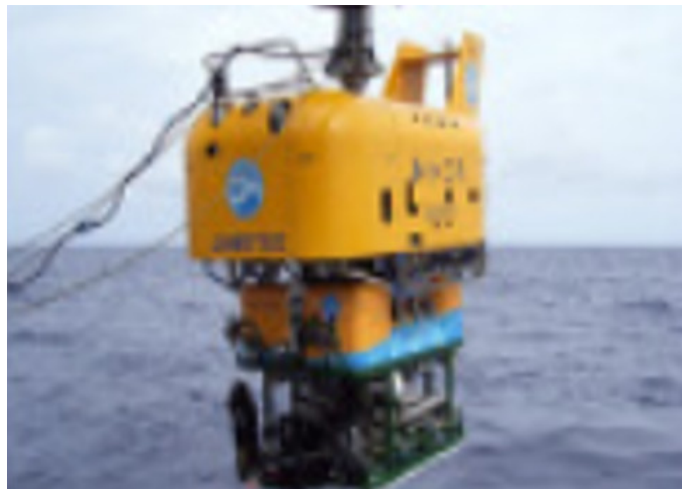

Source: Japan.

Figure 29: Fendouzhe.



Source: China.

Figure 30: Shinkai.

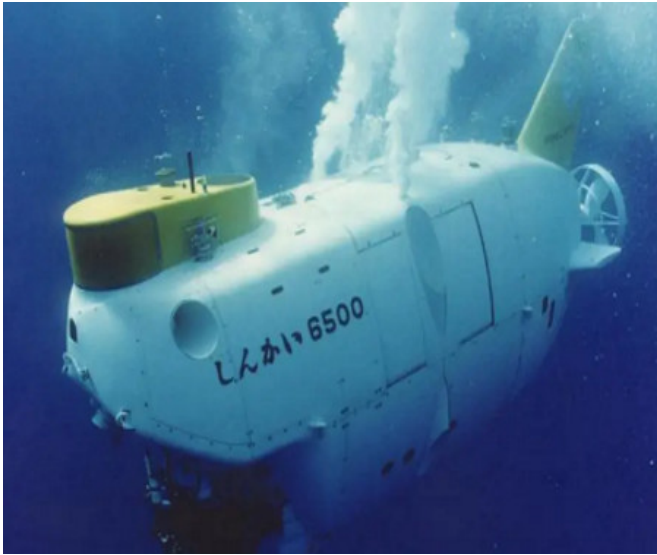

Source: Sadao Kawarma.

Figure 33: Ventana.



Source: MBARI.

Figure 31: Aqua Explorer.



Source: Kato et al.

Figure 34: ABE.



Source: Yoerger et al.

Figure 32: Twin Berger.



Source: Fuji et al.

Figure 35: ODIN.

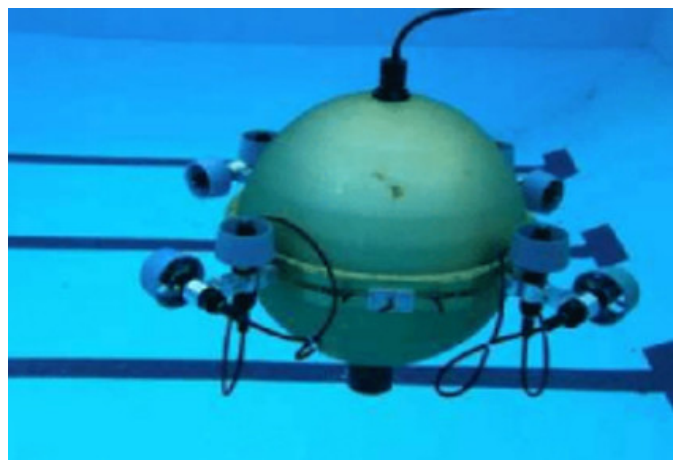

Source: Choi et al.

Figure 36: MARIUS.



Source: Pascoal et al.

Figure 39: HROV.

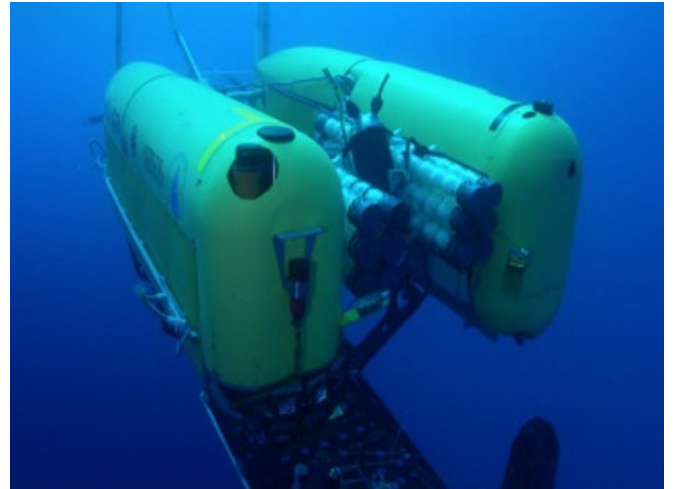

Source: JAMSTEC.

Figure 37: Parent-child.

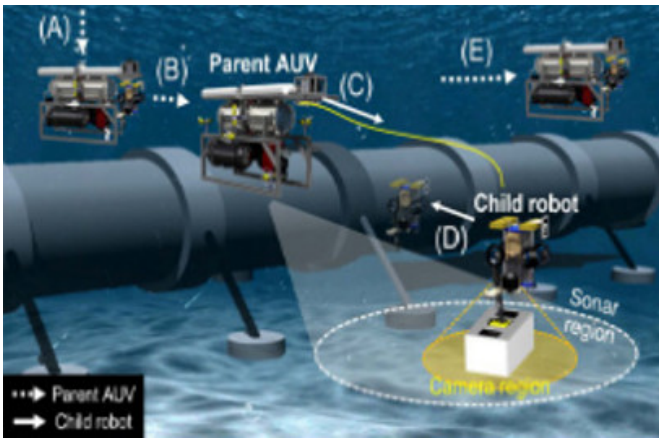

Source: Juhuwan Kim et al.

Figure 40: Blue ROV2.



Source: US based company.

Figure 38: VORTEX.



Source: Rigaud et al.

Figure 41: Notilo Plus.

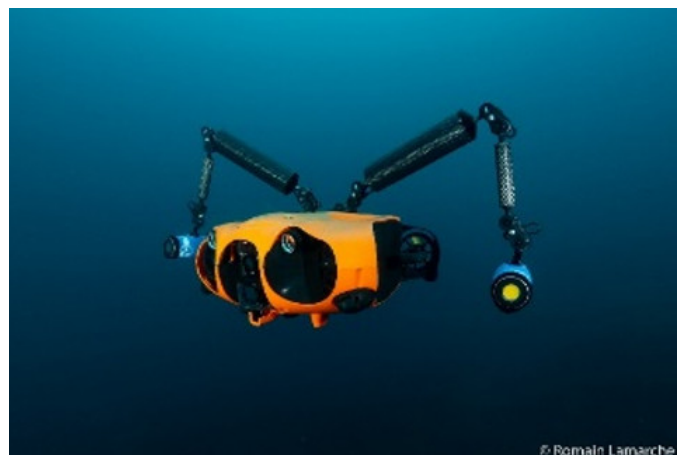

Source: French company.

Figure 42: Defender.



Source: US Company.

Figure 43: Qianlong.



Source: China.

Figure 44: Haido.



Source: China.

Table 11: Comparing the existing Under Water Bioinspired Robot.

Name	Qianlong	Haidao	Jiaolong	Bionic dolphine
Depth	6000 meters	7000meters	7,062meters	6meters
Length/diameter	4m/0.6meters	6m/0.8meters	8m/3meters	4meters
Weight	1500 kg	2500kg	22000kg	181kg
Type based on depth	Deep sea	Deepsea	Deepsea	Shallow
Developed by	China, Shenyang Institute of Automation	China, Shenyang Institute of Automation	China	Institute of Automation, CAS , China
depth:weight	4	2.8	0.32	0.33
Figure	42	43	44	45

Source: Authors.

Table 12: Comparing the existing Under Water Bioinspired Robot-Continuation.

Name	SOFI robotic fish	Robot jelly fish	Mantra Ray	Snake like water robot (eelume under water robot)	Humanoid robot under water: oceanonek
Depth	18 meters	300 meters	<1000 meters	500 meters (16400feet)	1000meters (3280feet)
Length/diameter	1 meter	1.2 meters	0.54meters	2-5meters Around 20cm(7.9inch)	1.5meters 5feet
Weight	2.5 kg	0.65kg	-	70-80 kilograms 154-176 pounds	250 kilograms 550 pounds
Type based on depth	Shallow	Shallow	Shallow	Mid – depth	Deep - sea
Developed by	MIT professor	Florida Atlantic University (FAU) and the U.S. Office of Naval Research scientists	ChenjieZhang et al	Norwegian company, in collaboration with kongsberg maritime and equinor	Stanford university
depth:weight	7.2	461.53	Ina	6.25	4
Figure	46	47	48	49	50

Source: Authors.

Figure 45: Jiulong.



Source: China.

Figure 46: Bionic Dolphine.



Source: CAS, China.

Figure 49: Mantra Ray.

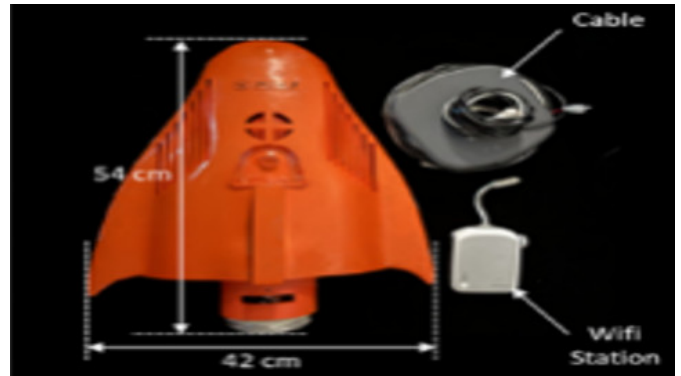

Source: ChenjieZhang et al.

Figure 47: SOFI.



Source: MIT Professors.

Figure 50: Snake robot.



Source: Norwagein company.

Figure 48: Jelly Fish.



Source: FAU Professors.

Figure 51: Humanoid Under water.



Source: Standford University.

2.4. Amphibious or Hybrid Water Robots.

Bayonet 250 [53] is an hybrid amphibious robotic crawler developed by GreenSealQ having a length of 2.5m and weight of 250kg as shown in Figure 51. Amphibious snake bot [54] developed by EPFL which is of length 0.7m and weight of 1.8kg can travel a depth of 1m as shown in Figure 52. Quadruped

Amphibious robot using duck feet was developed by Saad Bin-Abdul Kashem et al [55] is of length 0.4m and weight of 2.5kg as shown in Figure 53. Wheeled amphibious robot developed by Superdroid robot[56] as shown in Figure 54 is of 0.44 m length and weight of 11.3 kg can travel a depth of 1m. Helix Neptune[57] as shown in Figure 55 is another amphibious surface water robot which is of length of 2.4m and weight of 397kg was developed by Copperstone Technologies. Amphistar[58] as shown in Figure 56, is cockroach inspired amphibious surface water robot developed by Avi Cohen and David Zarrouk is of length 0.26m and weight of 0.246kg. Amphibious robot [59] using pool noodle wheel was developed by group of educators and makers in robot community is of length 0.5m and weight 2kg. Multicooperation of Turtle-inspired amphibious spherical robots developed by Liang Zheng et al [60] as shown in Figure 58, is of spherical shape with 0.3m as diameter. Honey Badger [61] as shown in Figure 59, is an amphibious robot developed by MAB robotics having a weight of 12kg and length of 0.6m. Spherical Amphibious Robot Vehicle (SARV)[62] as shown in Figure 60, developed by Guardbot having 0.4m diameter and 10kg as weight. Velox [61] is a creepy wiggly robot that moves in both land and water developed by US based pliant energy. Stevanus Satria, Lee Jia Wen, Samantha Chan [62] developed spherical amphibious robot weight 40-50kg and having diameter of 0.8m with capacity to reach 200m depth. Table 13-15 shows this type of robot.

Figure 52: Buyonet250.



Source: GreenSealQ.

Figure 53: Amphibious snake bot.



Source: EPFL.

Figure 54: Buyonet250.

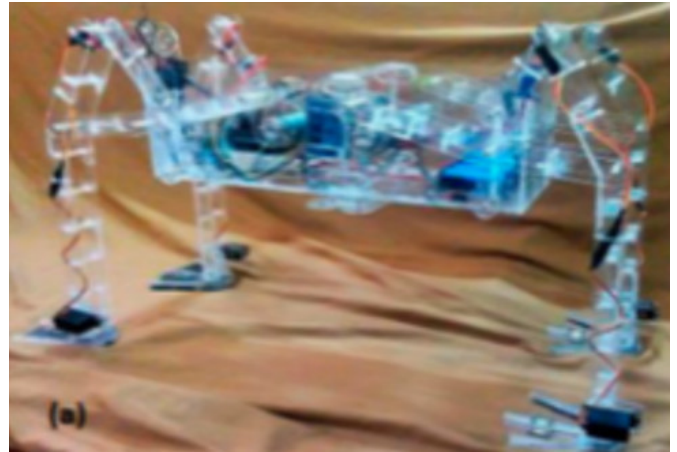

Source: Saad Bin Abdul Kashem et al.

Figure 55: Wheeled amphibious robot.



Source: Superdroid robot.

Figure 56: Helix Neptune.



Source: Copperstone technologies.

Figure 57: Amphistar.



Source: Avi Cohen & David Zarrouk.

Figure 58: Amphibious robot with pool noodle.



Source: Group of educators.

Figure 59: Turtle inspired robot.

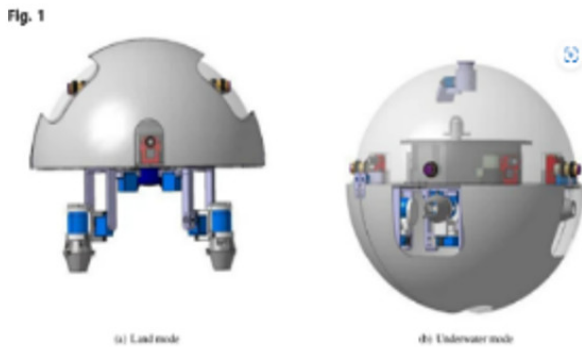

Source: MAB Robotics.

Figure 60: Honey Badger.

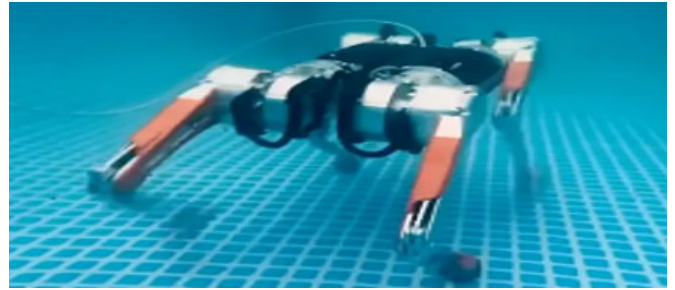

Source: Guardbot.

Figure 61: SARV.



Source: Guardbot.

Figure 62: Velox.



Source: US -pliant energy.

Figure 63: SAR.



Source: Stevanus Satria, Lee Jia Wen, Samantha Chan a.

Table 13: Comparing the existing Amphibious or hybrid Under Water Robot.

Name	Bayonet 250	Amphibious snake bot	Quadruped Amphibious Robot Using Duck Feet	Wheeled amphibious robot
Depth	100meters	1meters	Surface and land	1m
Length/diameter	2.5meters	0.7meters	0.4meters	0.44meters
Weight	250kg	1.8kg	2.5kg	11.3kg
Type based on depth	Shallow	Shallow		Shallow
Developed by	GreenSealQ	EPFL	Saad BinAbdul Kashem et al	Superdroid robot
depth:weight	0.4	0.55	0	0.08
Figure	51	52	53	54

Source: Authors.

Table 14: Comparing the existing Amphibious or hybrid Under Water Robot.

Name	Helix Neptune	Amphistar	Amphibious Robot Using Pool Noodle Wheels	Multicooperation of Turtle-inspired amphibious spherical robots
Depth	Surface water	-	-	-
Length/diameter	2.4 meters	0.26meters	0.5meters	0.3meters
Weight	397kg	0.246kg	2 kg	-
Type based on depth				
Developed by	Copperstone Technologies	Avi Cohen and David Zarrouk.	Educators and makers in robotics community	Liang Zheng
depth:weight	0	-	-	-
Figure	55	56	57	58

Source: Authors.

Table 15: Comparing the existing Amphibious or hybrid Under Water Robot-continuation.

Name	Honey Badger	Spherical Amphibious Robot vehicle	Velox	Spherical amphibious robot
Depth	-	surface	0.4 meters	200meters
Length/diameter	0.6meters	0.4meters	1.2meters	0.8meters
Weight	12 kg	10kg	40kg	40-50kg
Type based on depth	Shallow	shallow	shallow	shallow
Developed by	MAB Robotics	Guardbot	US based company	Stevanus Satria, Lee Jia Wen, Samantha Chan
depth:weight	-	0	0.01	4
Figure	59	60	61	62

Source: Authors.

Table 16: Comparing all types with respect to depth:weight value (d:w).

Robot Types	Count of types Taken for review	Count of types having d:w>10	Highest d:w	Name of Robot
Surface water	20	0	0.076	Waste Shark
Under water	23	5	66.66	Cotsbot
Bioinspired	09	1	461.33	Robot Jelly fish
Amphibious or hybrid	12	0	0.55	Amphibious snake robot

Source: Authors.

Figure 64: Comparative Analysis of various types of water robot with respect d:w (depth:weight) ratio.

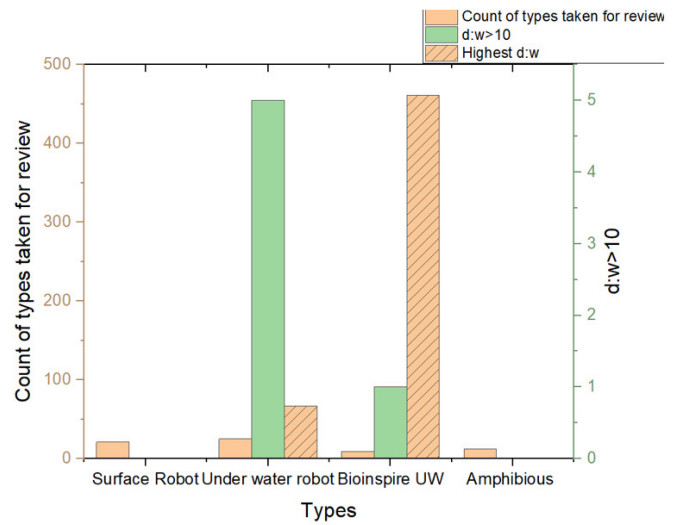

Source: Authors.

Conclusions.

Referring table 16 and Figure 63, it is clear that out of 64 different types of water robots considered for review across various types like surface robot, under water robot, under water bioinspired robot and amphibious or hybrid type of robot, the maximum count of robot types having d: w>10 value is of underwater types and if want to consider the highest d: w value, then it is from bioinspired under water robot (jelly fish type).

This gives a clear idea stating if water robot with high d:w value has to be designed, then the bioinspired underwater robot would be the better option.

Acknowledgements.

Need to acknowledge the contribution from all authors or designers of existing water robots for sharing their robot specification either through their research papers or website without which this review study could not been done.

References.

[1] Han, L. Y. (2024). The White Amur and the Waste-Shark: Hungry machines and circumventive remediations of waste. *Environment and Planning E: Nature and Space*, 251484-86241304970.

[2] Thomas, T., Bossens, D. M., & Tarapore, D. (2021, May). ASV Lite: a high-performance simulator for autonomous surface vehicles. In *2021 IEEE International Conference on Robotics and Automation (ICRA)*(pp. 2249-2255). IEEE.

[3] Rahmawati, E., Sucahyo, I., Asnawi, A., Faris, M., Taqwim, M. A., & Mahendra, D. (2019, December). A water surface cleaning robot. In *Journal of Physics: Conference Series*(Vol. 1417, No. 1, p. 012006). IOP Publishing.

- [4] Wang, H. H., Rock, S. M., & Lee, M. J. (1996). OTTER: The design and development of an intelligent underwater robot. *Autonomous Robots*, 3, 297-320.
- [5] Sun, X., Deng, H., Liu, G., & Deng, X. (2019). Combination of spatial and frequency domains for floating object detection on complex water surfaces. *Applied Sciences*, 9(23), 5220.
- [6] Qingdao Relong Technology Co., Ltd. (n.d.). Water surface garbage cleaning unmanned remote controlled boat harvester river cleaning machine. Made-in-China. <https://relog-tech.en.made-in-china.com/product/bdeaoOXbpMYq/China-Water-Surface-Garbage-Cleaning-Unmanned-Remote-Controlled-Boat-Harvester-River-Cleaning-Machine.html>.
- [7] Von Ellenrieder, K., & Wampler, J. (2016). Unmanned surface vessel (USV) systems for bridge inspection.
- [8] Gudmestad, O. T., Oma, B. T. F., Idrees, S., & Yousaf, M. U. (2024). Offshore Wind Turbines for the Norwegian Shelf.
- [9] ASV - Robot Systems: Robotics Innovation Center - DFKI GmbH.
- [10] Beatbot | Robotic Pool Cleaner, Pool Vacuum Robot & Skimmer
- [11] Wu, X., & Wang, S. (2024). Design and experiment of an intelligent surface mobile robot for the microbial slow-release control of pollution. *Journal of Computational Methods in Science and Engineering*, 24 (1), 547-557.
- [12] MIT SENSEable City Lab. (2010). Seaswarm prototype. Massachusetts Institute of Technology. https://senseable.mit.edu/seaswarm/ss_prototype.html.
- [13] Wullenweber, N., Hole, L. R., Ghaffari, P., Graves, I., Tholo, H., & Camus, L. (2022). SailBuoy ocean currents: low-cost upper-layer ocean current measurements. *Sensors*, 22 (15), 5553.
- [14] KOC Savunma. (n.d.). Smartium Clean. <https://www.kocsavunma.com/urunler-ve-hizmetler/sivil-projeler/smartium-clean.html>.
- [15] New Scientist. (2018). Swarm of robot wildlife will check for life in an Italian lagoon. <https://www.newscientist.com/article/2172391-swarm-of-robot-wildlife-will-check-for-life-in-an-italian-lagoon/>.
- [16] Water Intelligent. (n.d.). Unmanned pool cleaning robot DF-H7. <https://waterintelligent.com/product/factory-direct-explore-unmanned-pool-cleaning-robot-df-h7/>.
- [17] National Defense Magazine. (2024, March 29). Ukraine war fueling development of uncrewed surface boats as weapons. <https://www.nationaldefensemagazine.org/articles/2024-3/29/ukraine-war-fueling-development-of-uncrewed-surface-boats-as-weapons>.
- [18] Sunkara, V., Schmachtenberger, C., Rippey, W., van den Bergh, B., Lauwers, Q., Note, P. J., & McKenna, J. (2023, September). A Case-Study Based Overview of Unmanned Surface Vessel Design and Components. In *OCEANS 2023-MTS/IEEE US Gulf Coast* (pp. 1-9). IEEE.
- [19] Smith, R. N., Das, J., Hine, G., Anderson, W., & Sukhatme, G. S. (2011, September). Predicting wave glider speed from environmental measurements. In *OCEANS'11 MTS/IEEE KONA* (pp. 1-8). IEEE.
- [20] Zhu, J., Yang, Y., & Cheng, Y. (2022). SMURF: A fully autonomous water surface cleaning robot with a novel coverage path planning method. *Journal of Marine Science and Engineering*, 10(11), 1620.
- [21] Fernández-Perdomo, E., Cabrera-Gámez, J., Hernández-Sosa, D., Isern-González, J., Domínguez-Brito, A. C., Redondo, A., ... & García, M. (2010, May). Path planning for gliders using Regional Ocean Models: Application of Pinzón path planner with the ESEOAT model and the RU27 trans-Atlantic flight data. In *OCEANS'10 IEEE SYDNEY* (pp. 1-10). IEEE.
- [22] Glenn, S., Schofield, O., Kohut, J., McDonnell, J., Ludescher, R., Seidel, D., ... & Fanjul, E. (2011). The Trans-Atlantic Slocum glider expeditions: A catalyst for undergraduate participation in ocean science and technology. *Marine Technology Society Journal*, 45 (1), 52-67.
- [23] Abbasi, A., MahmoudZadeh, S., & Yazdani, A. (2020). A cooperative dynamic task assignment framework for COTS-Bot AUVs. *IEEE Transactions on Automation Science and Engineering*, 19(2), 1163-1179.
- [24] Griffiths, G. (2024). AUVs Under Ice: A Four-Decade Retrospective on Strategy and Risk Through the Autosub Looking Glass. *Marine Technology Society Journal*, 58(1-2), 38-51.
- [25] Sibenac, M., Kirkwood, W. J., McEwen, R., Shane, F., Henthorn, R., Gashler, D., & Thomas, H. (2002, October). Modular AUV for routine deep water science operations. In *OCEANS'02 MTS/IEEE* (Vol. 1, pp. 167-172). IEEE.
- [26] General Dynamics Mission Systems. (2025). Bluefin@-12 unmanned underwater vehicle (UUV) datasheet. <https://gd-missionsystems.com/-/media/general-dynamics/maritime-and-strategic-systems/bluefin/pdf/bluefin-12-uuv-datasheet.ashx>.
- [27] Alfred Wegener Institute. (n.d.). Bluefin-21 autonomous underwater vehicle (AUV). <https://epic.awi.de/id/eprint/40899/1/Bluefin-21-AUV.pdf>.
- [28] Michel, J. L., Klages, M., Barriga, F. J., Fouquet, Y., Sibuet, M., Sarradin, P. M., ... & Drogou, J. F. (2003, May). Victor 6000: design, utilization and first improvements. In *ISOPE International Ocean and Polar Engineering Conference* (pp. ISOPE-I). ISOPE.
- [29] Kyo, M., Hiyazaki, E., Tsukioka, S., Ochi, H., Amintani, Y., Tsuchiya, T., ... & Takagawa, S. (1995, October). The sea trial of "KAIKO", the full ocean depth research ROV. In 'Challenges of Our Changing Global Environment'. *Conference Proceedings. OCEANS'95 MTS/IEEE* (Vol. 3, pp. 1991-1996). IEEE.
- [30] YANG, B., LIU, Y., & LIAO, J. (2021). Manned submersibles—deep-sea scientific research and exploitation of marine resources. *Bulletin of Chinese Academy of Sciences (Chinese Version)*, 36(5), 622-631.
- [31] Hotta, S., Mitsui, Y., Suka, M., Sakagami, N., & Kawamura, S. (2023). Lightweight underwater robot developed for archaeological surveys and excavations. *Robomech Journal*, 10 (1), 2.
- [32] Kato, N., Ito, Y., Kojima, J., Takagi, S., Asakawa, K., & Shirasaki, Y. (1994, September). Control performance of autonomous underwater vehicle "Aqua Explorer 1000" for inspection of underwater cables. In *Proceedings of OCEANS'94* (Vol. 1, pp. I-135). IEEE.

- [33] Balasuriya, B. A. A. P., Fujii, T., & Ura, T. (1995, August). A vision-based interactive system for underwater robots. In *Proceedings 1995 IEEE/RSJ International Conference on Intelligent Robots and Systems. Human Robot Interaction and Cooperative Robots* (Vol. 2, pp. 561-566). IEEE.
- [34] Reisenbichler, K. R., Chaffey, M. R., Cazenave, F., McEwen, R. S., Henthorn, R. G., Sherlock, R. E., & Robison, B. H. (2016, September). Automating MBARI's midwater time-series video surveys: The transition from ROV to AUV. In *OCEANS 2016 MTS/IEEE Monterey* (pp. 1-9). IEEE.
- [35] Yoerger, D. R., Bradley, A. M., Walden, B. B., Cormier, M. H., & Ryan, W. B. (2000, April). Fine-scale seafloor survey in rugged deep-ocean terrain with an autonomous robot. In *Proceedings 2000 ICRA. Millennium Conference. IEEE International Conference on Robotics and Automation. Symposia Proceedings (Cat. No. 00CH37065)* (Vol. 2, pp. 1787-1792). IEEE.
- [36] Choi, H. T., Hanai, A., Choi, S. K., & Yuh, J. (2003, October). Development of an underwater robot, ODIN-III. In *Proceedings 2003 IEEE/RSJ International Conference on Intelligent Robots and Systems (IROS 2003) (Cat. No. 03CH37453)* (Vol. 1, pp. 836-841). IEEE.
- [37] Oliveira, P., Pascoal, A., Silva, V., & Silvestre, C. (1996, September). Design, development, and testing at sea of the mission control system for the MARIUS autonomous underwater vehicle. In *OCEANS 96 MTS/IEEE Conference Proceedings. The Coastal Ocean-Prospects for the 21st Century* (Vol. 1, pp. 401-406). IEEE.
- [38] Kim, J., Kim, T., Song, S., Sung, M., & Yu, S. C. (2023). Parent-child underwater robot-based manipulation system for underwater structure maintenance. *Control Engineering Practice*, 134, 105459.
- [39] Rigaud, V., Le Rest, E., Marce, L., Maniere, E. C., Simon, D., Peuch, A., & Perrier, M. (1994, April). VORTEX: Versatile and open subsea robot for technical experiment: Prototyping software architecture for the next AUV and ROV generation. In *ISOPE International Ocean and Polar Engineering Conference* (pp. ISOPE-I). ISOPE.
- [40] Schmidt Ocean Institute. (n.d.). Robotic platforms. <https://schmidtocean.org/technology/robotic-platforms/>.
- [41] Wilby, A., & Lo, E. (2020, September). Low-cost, open-source hovering autonomous underwater vehicle (hauv) for marine robotics research based on the bluerov2. In *2020 IEEE/OES Autonomous Underwater Vehicles Symposium (AUV)* (pp. 1-5). IEEE.
- [42] NVIDIA Corporation. (n.d.). Jetson solution showcase: Notilo (PDF). https://developer.download.nvidia.com/assets/embedded/downloads/jetson_solution_showcase-notilo.pdf.
- [43] Unmanned Systems Technology. (n.d.). Mission Specialist Defender (VideoRay). <https://www.unmannedsystems-technology.com/company/videoray/mission-specialist-defender>.
- [44] Wu, J., Liu, J., & Xu, H. (2014, April). A variable buoyancy system and a recovery system developed for a deep-sea AUV Qianlong I. In *Oceans 2014-Taipei* (pp. 1-4). IEEE.
- [45] Cociani, R. (2020, June 17). China deploys new Haidou-1 deepwater AUV. Jane's Defence News. <https://www.janes.com/osint-insights/defence-news/china-deploys-new-haidou-1-deepwater-auv>.
- [46] Dou, X., Wang, Y., & Fang, Y. (2023). A Brief History of Robotics Development of CAS. In *State-of-the-Art and Innovations in Mechanism and Machine Science: A Tribute to Carlos López-Cajún* (pp. 77-87). Cham: Springer Nature Switzerland.
- [47] Zhang, Y., Wu, Z., Wang, J., & Tan, M. (2023). Design and analysis of a bionic gliding robotic dolphin. *Biomimetics*, 8(2), 151.
- [48] Salazar, J. (2022). *Computational Design and Control of Autonomous Underwater Vehicles* (Doctoral dissertation, Massachusetts Institute of Technology).
- [49] Sproul, J., Pedlikin, J., & Engeberg, E. D. (2024). Sea-Jelly Innovation Empowers STEM Education. *Naval Engineers Journal*, 136(3), 183-188.
- [50] Zhou, X., Li, K., Liu, Y., Sun, J., Li, H., Chen, W., & Deng, J. (2022). Development of an antihydropressure miniature underwater robot with multilocomotion mode using piezoelectric pulsed-jet actuator. *IEEE Transactions on Industrial Electronics*, 70(5), 5044-5054.
- [51] Kelasidi, E., Liljebäck, P., Pettersen, K. Y., & Gravadahl, J. T. (2016). Innovation in underwater robots: Biologically inspired swimming snake robots. *IEEE robotics & automation magazine*, 23(1), 44-62.
- [52] Yeh, X. (2017). *Development of an underwater humanoid robotic diver* (Doctoral dissertation, Stanford University).
- [53] Greensea IQ. (n.d.). Bayonet 250 data product sheet. https://greenseaiq.com/wp-content/uploads/2024/05/data_product_sheet_bayonet250_v2-copy.pdf.
- [54] EPFL Biorobotics Laboratory. (n.d.). Amphibot: An amphibious snake robot. École Polytechnique Fédérale de Lausanne. <https://www.epfl.ch/labs/biorob/research/amphibious/amphibot/>.
- [55] Kashem, S. B. A., Jawed, S., Ahmed, J., & Qidwai, U. (2019). Design and implementation of a quadruped amphibious robot using duck feet. *Robotics*, 8(3), 77.
- [56] SuperDroid Robots. (n.d.). Product 2121. <https://www.superdroidrobots.com/store/product=2121>.
- [57] Olmedo, N. A., Lipsett, M. G., Yuen, J., & Milne, C. (2022). Towards autonomous tailings and pit lake monitoring with amphibious robots.
- [58] Cohen, A., & Zarrouk, D. (2020, October). The Amphistar high speed amphibious sprawl tuned robot: Design and experiments. In *2020 IEEE/RSJ International Conference on Intelligent Robots and Systems (IROS)* (pp. 6411-6418). IEEE.
- [59] Day, L. (2021, August 18). Build an amphibious robot using pool noodles for wheels. Hackaday. <https://hackaday.com/2021/08/18/build-an-amphibious-robot-using-pool-noodles-for-wheels/>.
- [60] Zheng, L., Guo, S., Piao, Y., Gu, S., & An, R. (2020). Collaboration and task planning of turtle-inspired multiple amphibious spherical robots. *Micromachines*, 11(1), 71.
- [61] MAB Robotics. (n.d.). Honey Badger: Legged robot platform. <https://www.mabrobotics.pl/robotics/honey-badger>.
- [62] Krieger, K. (2013). Meet GuardBot.

[63] Dezeen. (2019, February 7). Amphibious Velox robot uses undulating fins to swim and crawl. <https://www.dezeen.com/2019/02/07/amphibious-velox-robot-technology/>.

[64] Satria, S., & Wen, L. J. (2015). Portable amphibious

spherical rolling robot with live-streaming capability for ground and aquatic deployment. In *IRC Conference on Science, Engineering, and Technology, Singapore*.